

CORTE F-F

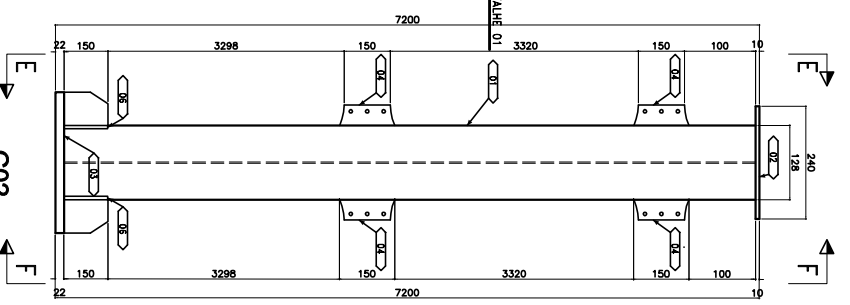

CORTE C-C

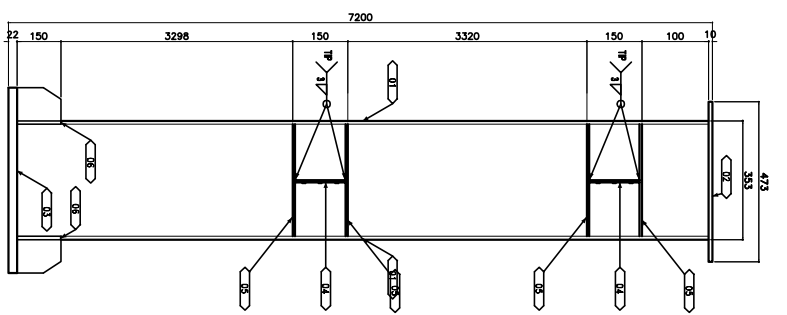

CORTE E-E

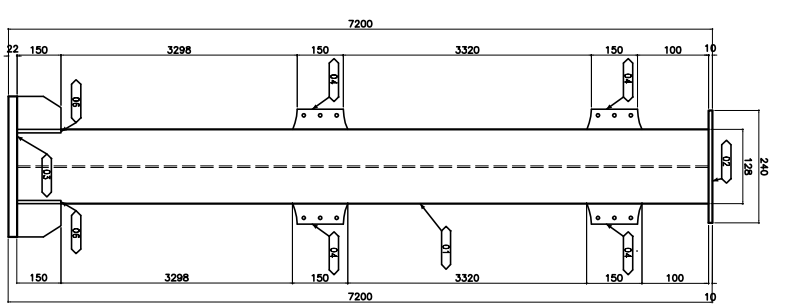

CORTE D-D

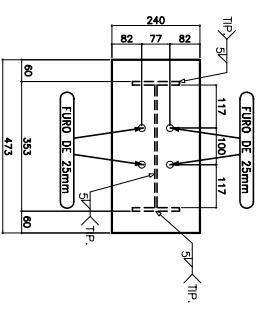

**CORTE B-B
TOPO DA COLUNA**

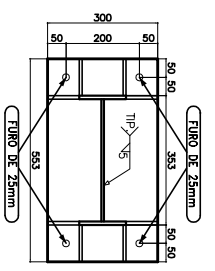

**CORTE A-A
BASE DA COLUNA**

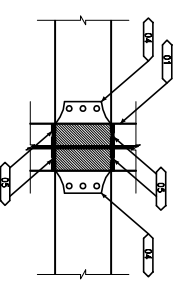

**VISTA LATERAL
DA LIGAÇÃO
COLUNA-TERÇA**

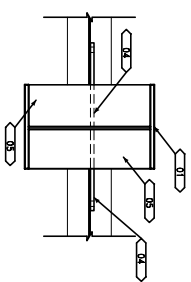

**VISTA SUPERIOR
DA LIGAÇÃO
COLUNA-TERÇA**

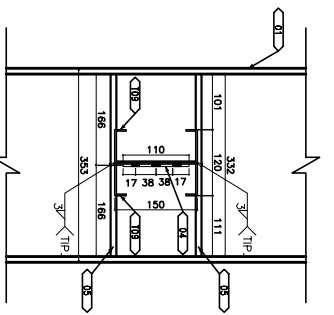

**DETALHE 01
LIGAÇÃO COLUNA-TERÇA**

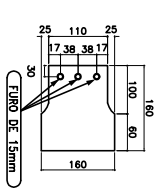

**DETALHE
PEÇA 04**

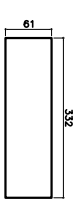

**DETALHE
PEÇA 05**

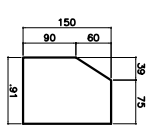

**DETALHE
PEÇA 06**

QUANTITATIVO

POS.	QTD.	DESCRIÇÃO	PESO UNITARIO	PESO TOTAL
01	01	W 360 x 39 x 7168	39,00	279,55
02	01	CH 473 x 270 # 12,7mm	12,73	12,73
03	01	CH 553 x 300 # 22,0mm	28,65	28,65
04	04	CH 160 x 160 # 8,0mm	1,60	6,40
05	08	CH 332 x 61 # 8,0mm	1,27	10,16
06	08	CH 150 x 100 # 6,30mm	0,74	5,92
02		COLUNA 02	343,41	686,82
			PESO UNITARIO	686,82
			PESO TOTAL	686,82

NOTAS:
MEDIDAS EM MILÍMETROS, EXCETO ANOTADO.

REV. Nº	DESCRIÇÃO	DATA

PREFEITURA DO MUNICÍPIO DE VARGINHA
SEPLA - SECRETARIA MUNICIPAL DE PLANEJAMENTO URBANO

ENGENHEIRO: **EINEI HORTENCIA CORINA FERREIRA** DATA: **JULHO/2017**

PROPRIETÁRIO: **PREFEITURA MUNICIPAL DE VARGINHA** DESENHO: **MARCELL**

AUTOR DO PROJETO: **JONATHAS LEÃO SOARES** ARQUITETO: **Jonathas Leão Soares**

TÍTULO: **DESENHO DE FABRICAÇÃO - COLUNA 02** CREA: **129102D**

FRANQUIA: **CONTEUDO DA FRANQUIA** DESENHO DE FABRICAÇÃO - COLUNA 02

11/21